

International Journal of Engineering Sciences & Research Technology

(A Peer Reviewed Online Journal)
Impact Factor: 5.164



Chief Editor
Dr. J.B. Helonde

Executive Editor
Mr. Somil Mayur Shah

We all are quite familiar with electronic voting machines, where our votes get registered electronically and don't need to use ballot paper to vote in election. Today security is a major concern and it also needs to be ensure that someone can't vote twice, so this problem can be solved by introducing face recognition and fingerprint based voting system, where a person can be authorized based on his/her fingerprint and face.

KEYWORDS: fingerprint technique^[1], face recognition, and Image processing.

1. INTRODUCTION

Electronic voting machine^[4] has already been developed and used in many developed countries. But most of them use RFID and some of them use image processing to detect citizens. But only image processing^[3] is not enough. Keeping these issues in mind we have got developed this project wherever raspberry pi are used as host.

The raspberry pi may be a master card sized single laptop or soc uses ARM1176JZF-S core. System on a chip (soc) may be a technique of putting all necessary natural philosophy for running a laptop on one chip. A camera is used to the face recognition of citizens with image processing technique. Each voting machine is locked by fingerprint access module^[1]. As the user identified his/her fingerprint will be sent to the machine for voting. Each voting machine is networked with the central voting identification system.

2. MATERIALS AND METHODS

Materials

1. Raspberry pi 3B+
2. Arduino UNO
3. 720P Camera
4. R307 FP module
5. 16×4 LCD Display
6. Push on buttons
7. LED
8. Power supply
9. Software :- python, arduino embedded c

Face recognition

Facial recognition is a way of recognizing a human face through technology. A face recognition system^[2] uses biometric to map countenance from a photograph or video. It compares the data with a data base of glorious faces to search out a match. Facial recognition can help verify personal identity. Both verification and identification of face is done in the face recognition module. This is done by image acquisition and image processing^[3]. In image processing technique first convert the signals from an image sensor (camera) into digital images. Then improves the clarity and remove noise and other artifacts. After that extract the size, scale or number of object in a scene and prepare images for display or prints. Finally compress images for communication across a network.

Figure:

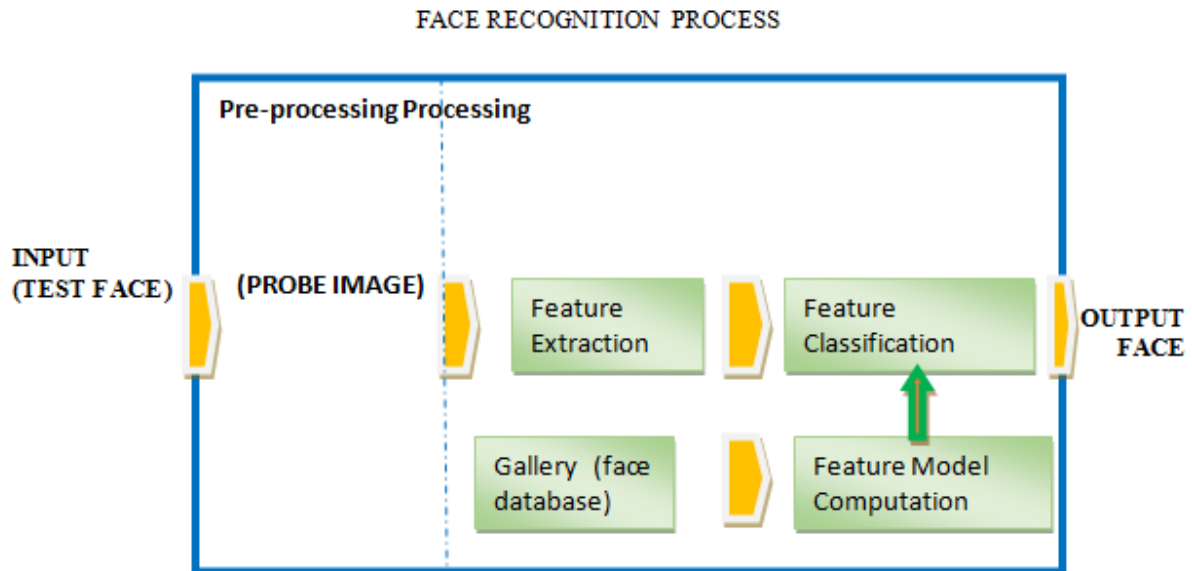
**Fingerprint recognition**

Another biometric way is fingerprint; the fingerprint scanner consists of fingerprint sensor, A/D converter, flash ROM and DSP chip.

Sensor: - the sensor scanning the thumb impression, scanning data is in the form analog.

A/D converter: - convert analog data to digital and transform to processor.

Flash ROM: - this store the data temporarily in DSP process and this will work until the data transform to the main memory of the HOST.

DSP chip: - processing and receiving the data.

DSP port: - it is used for the communication between DSP process and memory (data base).

The extension of thumb impression from the memory is that the next method. In the kind of pixels the fingerprints area unit keep within the future. The pixels area unit sent to the pattern matching then the fingerprint is compared with the information records. If the fingerprint pattern is matched with the records then the citizen can vote. If it is not matched with the record, then the citizen can't vote.

Figure

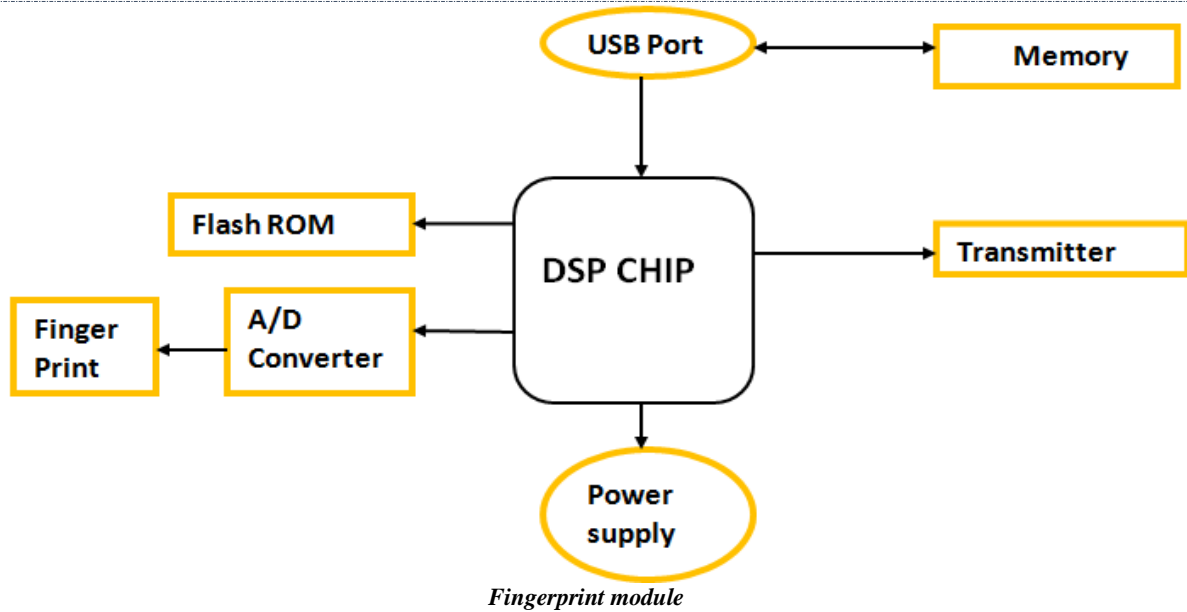

3. RESULTS AND DISCUSSION

After fingerprint recognition and face recognition the citizen can vote only if the finger print and face are match with that in the data base. If the citizen is eligible for voting then the LCD will display in the control unit. Then the person can vote, according to the vote the LCD in the ballot unit will display the symbol of candidate which the citizen was voted.

Control unit

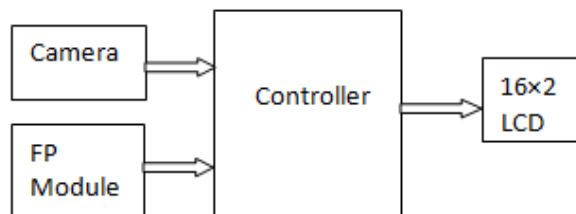

Ballot unit

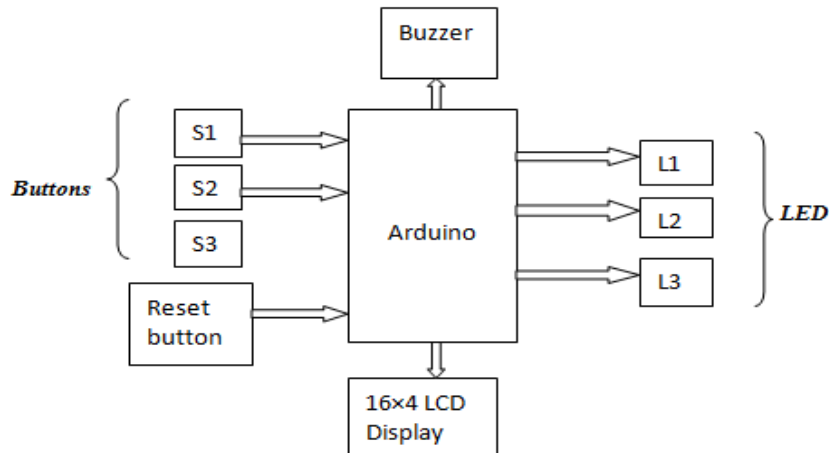

4. CONCLUSION

In total, this system overcomes most of the issues faced during the voting period by the paper ballot system^[5]. This will for sure guarantee a safer voting method that is incredibly abundant what is needed for a healthy growth of a developing nation. In this project, the proposed fingerprint and face recognition based voting system which is better and faster than previous system. The new system prevents access to illegal voters; provide ease of use, transparency and maintaining integrity of the voting process. The system also prevents multiple votes by the same person and checks eligibility of the voter.

5. ACKNOWLEDGEMENTS

This research was partially supported by college of engineering perumon, our HOD Dr.R Bijukumar and our prof.Surjith s. We area unit glad to our colleagues, teachers provided experience that greatly aided the analysis.

We thank prof. Renjith for assistance with project and prof. Kannan, college of engineering perumon for comments that greatly improved the manuscript. We are also immensely grateful to prof. Surjith s for his comments on an earlier version of the manuscript. Finally we would like to thank God.

REFERENCES

- [1] A review paper on finger print identification system : Priyanka rani,Pinki sharma
- [2] A survey paper for face recognition technologies : Kavita
- [3] Digital image processing techniques- a survey : S.muthuselvi, P.prabhu
- [4] Electronic voting machine-a review : Ashok kumar D, Ummal sariba begum T
- [5] Understanding the security properties of ballot- based verification techniques : Eric rescorla
- [6] <http://www.slideshare.net>
- [7] <http://en.m.wikipedia.org>
- [8] <http://www.researchgate.net>
- [9] www.edgefx.in
- [10] Iosrjournals.org>papers>version-2
- [11] Ijarcet.org>wp-content>uploads
- [12] <http://www.quora.com>
- [13] <http://www.engineersgarage.com>